

INSTALLATION INSTRUCTIONS SAMPLE MASTER FILTER 420



41041 Black Bayou Rd, Gonzales, Louisiana, USA 70737
Phone (225) 644-5255 FAX (225) 644-3975
www.geniefilters.com sales@geniefilters.com

Revision 6.06

The Sample Master Filter Model 420 is a "T" type design filter housing that accommodates the Ultra Glysorb cartridges. The filter has 1/4" female NPT connections, and it is comprised of two parts (head and bowl)

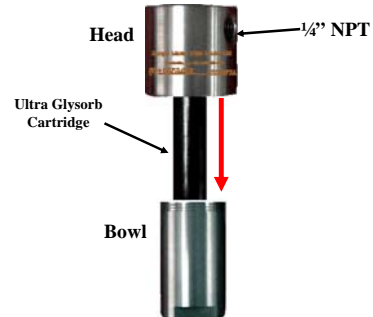

It may be disassembled by grasping the bowl by hand and turning counterclockwise. Filter cartridges may be installed as follows. Remove all sources of pressure from the SMF Model 420 (fittings need not be removed). Insert one end of the cartridge into the head of the filter. Slide the cartridge in until it bottoms into the head.

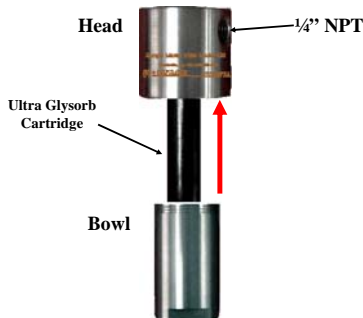

Replace the bowl and hand-tighten by turning clockwise. The filter may be installed in-line using 1/4" NPT male adapters.

CAUTION:
Max Pressure=5000 PSI



Refer to the literature supplied with the cartridge for specific cartridge application information

*Replacement O-rings are available.
Part Number 420-500 O-ring Kit contains 5 EA.*

SAMPLE MASTER FILTER 420 (CUTAWAY VIEW)

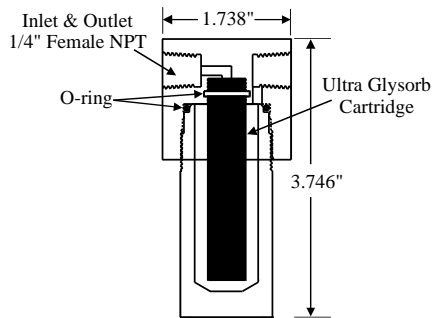

SEE OUR WEBSITE FOR OTHER PRODUCTS & LITERATURE
AVAILABLE FROM A+ CORPORATION

www.geniefilters.com

Moisture and Corrosion Control Products - Request Brochure B-MCC

Natural Gas Industry Products (including 410 & Glysorb) - Request Brochure B-NGI

Analyzer Application Notes - Consult A+ Corporation technical support for specific applications

Series 100 (Gas/Liquid) Genie Membrane Separators - Request Brochure B-100

Series 200 (Liquid/Liquid) Genie Membrane Separators - Request Brochure B-200

Diaphragm Sample Pump - Request Application Note and Installation Instructions

140 Series Membrane Separator Probes (Ambient Air Monitoring Filters) - Request Brochures B-142 and B-143