

GENIE®

cal port housing



U.S. Patents 6,357,304; 6,701,794; 6,904,816; 7,004,041

Applications

- ▶ Testing and verification of sample conditioning systems
 - ▶ Moisture and BTU
- ▶ Drying down or purging contaminated sample conditioning systems

Benefits

- ▶ Entire SCS is tested
 - ▶ From probe tip to analyzer inlet
- ▶ Capability to perform sampling and performance testing with one housing
- ▶ Helps to preserve sample integrity

Features

- ▶ Test gas injection port
- ▶ Vibration resistant
- ▶ No dead volume
- ▶ Low internal volume

Quick Study

The analyzer sample conditioning system (SCS) can be the source for many of the analytical errors involved in the natural gas, process, and petrochemical industries. Testing and verifying the performance of SCS would be of considerable value and should become a common practice to help ensure that an accurate compositional analysis is obtained. In order to carry out the SCS performance testing, a need exists for equipment that would allow a performance test gas (moisture standard, calibration gas, or specified blend) to be injected at the entrance of the SCS (i.e. probe tip) so that the entire SCS can be exposed to the test gas.

The Cal Port Housing accomplishes this task, and should be used in place of the standard Genie® Membrane Probe™ Housing when there is a desire to carry out both sampling and performance testing with only one probe housing. The design of the Cal Port housing is similar to the housing for a Genie® Membrane Probe™ (Model GP2 or GPR), with an additional “calibration” port on the side. The sample gas flow can be blocked by the housing’s “foot valve”, allowing a test gas of desired pressure to be introduced through the calibration port and into the probe tip for the purpose of performance testing the entire SCS. The Cal Port housing can also be used to dry down or purge a system that has been contaminated with moisture or hydrocarbon liquid.

Technical Specifications

Maximum pressure rating	3,500 psig
Maximum temperature	185 °F (85 °C)
Maximum recommended flow rate (for higher flow rates contact the factory)	6 L/min for BTU membrane* 18 L/min for Hi-Flow Backed membrane* <small>*Maximum flow results in approximately 2 psi membrane differential pressure</small>
Internal volume	13.758 cc
Calibration gas port size	1/8" female NPT
Process connection	3/4" male NPT
Thread-o-let requirement	3/4" female NPT* <small>*Inner diameter must not be less than 0.910"</small>
Wetted materials	Machined parts: 316 stainless steel / NACE compliant All other metal parts: stainless steel / NACE compliant Foot Valve sealing material: Kalrez standard Probe sealing material: Neoprene standard



An ISO 9001:2000 certified company



Genie®, Genie® Membrane Probe™, Genie® Probe Regulator™, GPiL™, GPRiL™, GPR™, GP2™, PIP™ and Genie® Membrane Technology™ are trademarks or registered trademarks of A+ Corporation, LLC. All other referenced trademarks are the property of their respective owners.



Model Numbering & Additional Part Numbers

Your model number is determined by your specific needs. Choose options below.

Sealing material 	0 = Neoprene	<i>(other materials available upon request)</i>	
Probe housing length	Blank = 4"	B = 7"	C = 9"

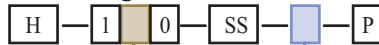
How to build the Genie® housing model number:



 We cannot recommend specific sealing materials due to the complex nature of sample stream compositions. Temperature and pressure also may be factors.
 Unless specified otherwise, the product will ship with our standard sealing materials and materials of construction stated in the technical specifications section of the corresponding Product Sheet.  Please refer to www.dupontelastomers.com for sealing material recommendations and advice. It is the user's responsibility to specify the sealing materials and other materials of construction for their application.

Dimensions

Front View

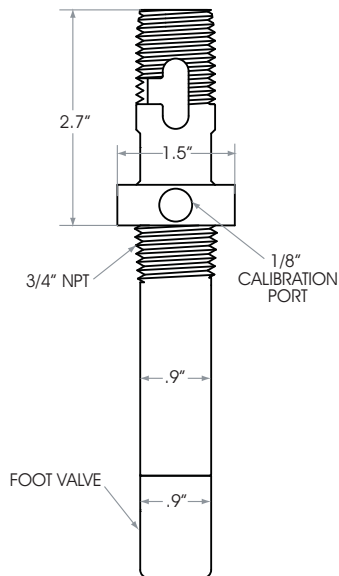

Side View

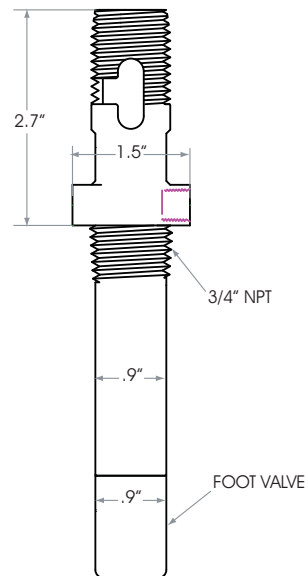

Local Distributor:

Manufacturer

A+ Corporation, LLC

41041 Black Bayou Road

Gonzales, LA 70737

Call for expert product application assistance:

Phone: (225)-644-5255 Website: www.geniefilters.com

Fax: (225)-644-3975 E-mail: sales@geniefilters.com



An ISO 9001:2000 certified company

©2010 A+ Corporation, LLC. All rights reserved.

SCC-CalPort-PS_0310